

TECHNICAL MANUAL

**OPERATOR'S, ORGANIZATIONAL, DIRECT SUPPORT
AND GENERAL SUPPORT MAINTENANCE
MANUAL INCLUDING REPAIR PARTS LIST**

FOR

**DEGREASER
MODEL HT20
(NSN 4940-00-276-8868)
(KLEER-FLO COMPANY)**

HEADQUARTERS, DEPARTMENT OF THE ARMY

JULY 1981

WARNING

Make certain that no open flame, sparks or smoking materials are in the vicinity of the degreaser. Protective clothing such as aprons, face shields and solvent resistant gloves should be utilized if instructions for use of solvent so indicate. Use only solvents listed on warning plate. Cover of degreaser should be closed when not in use.

Technical Manual }
No. 9-4940-524-14&P }

HEADQUARTERS
DEPARTMENT OF THE ARMY
Washington, DC, 31 July 1981

**OPERATOR'S, ORGANIZATIONAL, DIRECT SUPPORT
AND GENERAL SUPPORT MAINTENANCE
MANUAL INCLUDING REPAIR PARTS LIST**

FOR

**DEGREASER
MODEL HT20
(NSN 4940-00-276-8868)**

REPORTING OF ERRORS

You can help improve this manual. If you find any mistakes or if you know of a way to improve the procedures, please let us know. Mail your letter, DA Form 2028 (Recommended Changes to Publications and Blank Forms), or Form 2028-2, located in the back of this manual direct to: Commander, US Army Armament Materiel Readiness Command, ATTN: DRSAR-MAS, Rock Island, IL 61299. A reply will be furnished directly to you.

NOTE

This manual is published for the purpose of identifying an authorized commercial manual for the use of the personnel to whom this degreaser is issued.

Manufactured by: Kleer-Flo Company
6600 Washington Ave. S.
Eden Prairie, Minnesota 55344

Procured under Contract No. DAAA09-79-C-4121

This technical manual is an authentication of the manufacturers' commercial literature and does not conform with the format and content specified in AR 310-3, Military Publications. This technical manual does, however, contain available information that is essential to the operation and maintenance of the equipment.

INSTRUCTIONS FOR REQUISITIONING PARTS

NOT IDENTIFIED BY NSN

When requisitioning parts not identified by National Stock Number, it is mandatory that the following information be furnished the supply officer.

- 1 - Manufacturer's Federal Supply Code Number - 16649
- 2 - Manufacturer's Part Number exactly as listed herein.
- 3 - Nomenclature exactly as listed herein, including dimensions, if necessary.
- 4 - Manufacturer's Model Number - Model HT20
- 5 - Manufacturer's Serial Number (End Item)
- 6 - Any other information such as Type, Frame Number, and Electrical Characteristics, if applicable.
- 7 - If DD Form 1348 is used, fill in all blocks except 4, 5, 6, and Remarks field in accordance with AR 725-50.

Complete Form as Follows:

(a) In blocks 4, 5, 6, list manufacturer's Federal Supply Code Number - 16649 followed by a colon and manufacturer's Part Number for the repair part.

(b) Complete Remarks field as follows:
Noun: (nomenclature of repair part)
For: NSN: 4940-00-276-8868
Manufacturer: Kleer-Flo Company

Model: HT20
Serial: (of end item)

Any other pertinent information such as Frame Number, Type, Dimensions, etc.

OPERATING INSTRUCTIONS DEGREASER, PORTABLE, SOLVENT TYPE, TANK IMMERSION

Description: The degreaser conforming to the referenced specification consists of a rectangular 16 gal. mild steel tank 102" long, 10" wide and 12" deep. It is equipped with a cover hinged along the length dimension incorporating a fusible link assembly permitting the cover to close automatically in the event of fire.

The tank is liquid tight and is equipped with a drain valve, an inlet hose with strainer to pump and a discharge hose and nozzle providing accessibility to the full working area of the tank. A frame supporting the tank is equipped with 3" swivel casters and acts as the support for the motor and pump assembly with foot switch for ease of operation. Two work rests and one parts basket are provided. The work rests support the basket and large parts from the bottom of the tank.

Operation:

1. Make certain that electrical current available is 115 v. 60 hz., single phase.
2. If degreaser is to be used in a confined area, a forced ventilation system shall be provided.
3. Make certain that drain valve is closed and fill tank with recommended solvent to fill line.
4. Parts are cleaned by immersing in solvent or through direction of solvent flow from the hose and nozzle.

Trouble Shooting:

- A. If flow from nozzle diminishes significantly or ceases, check inlet strainer to make sure it is free flowing and not clogged in any way.
- B. If strainer is clean, disconnect from electrical power source, remove solvent from tank.
- C. Remove discharge and inlet hoses to make certain there are no blockages in the interior.
- D. Examine pump to make sure inlet is not clogged and rotor is not loose on drive shaft.
- E. If all these parts are in good working order, have qualified electrician check power source, outlet box, all wiring, foot switch and motor.

Repair: The motor of the degreaser is an explosion-proof, totally sealed unit and should not require any periodic maintenance. Should failure occur with the motor or foot switch, repair should be undertaken by a qualified electrician.

Should the tank ever develop a leak due to corrosive residues, welding or brazing will correct the condition. Rubber discharge hose can be easily replaced if worn after extended use.

Parts Listing: A complete parts list is included showing Part No., Fig. and Index No. and quantity per assembly.

WARNING

Make certain that no open flame, sparks or smoking materials are in the vicinity of the degreaser. Protective clothing such as aprons, face shields and solvent resistant gloves should be utilized if instructions for use of solvent so indicate. Use only solvents listed on warning plate. Cover of degreaser should be closed when not in use.

Cleaning & Lubrication: Lubrication is not required.

- A. When time for clean-out is indicated by sludge build up, etc remove basket and work rests.
- B. Use pump to transfer solvent to disposal container until fluid level reaches point where flow diminishes.
- C. Turn off pump and place suitable disposable container on frame under drain valve.
- D. Open drain valve to remove last portion of solvent.
- E. Clean out sludge from tank and clean strainer.
- F. Put in fresh solvent according the instructions under operation.

Illustration: Illustration of degreaser is included in this manual.

CAUTION

If Degreaser is moved to another location, make sure that electrical current is correct for machine (see Operation).

WARNING

Ventilation requirements and fire precautions must be observed.

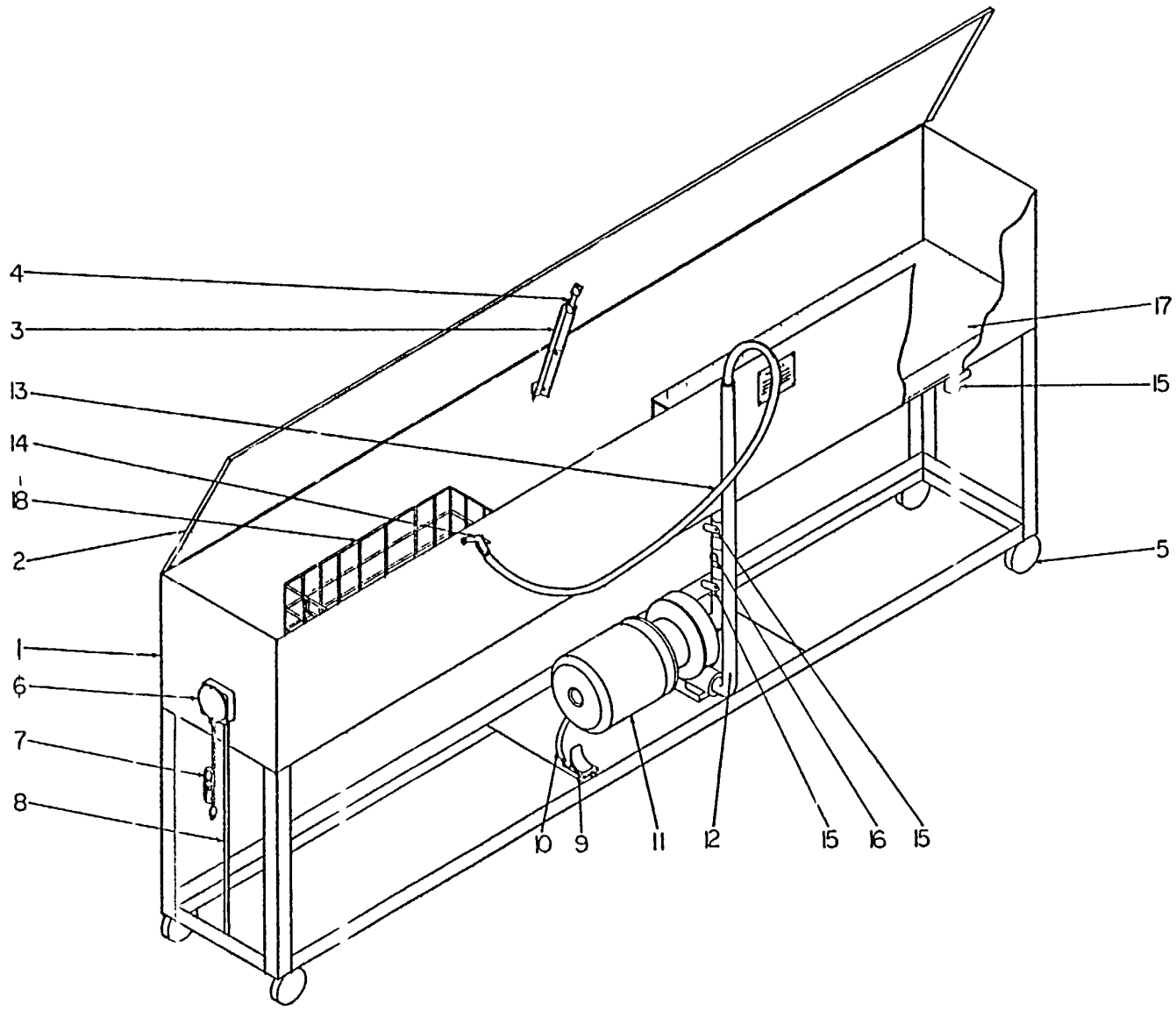

Figure 1. Parts Diagram
 DEGREASER, PORTABLE, SOLVENT TYPE,
 TANK IMMERSION, MODEL-HT20

FIGURE & INDEX NUMBER	PART NUMBER	DESCRIPTION	UNITS PER ASSY
-1	20-01	CABINET	1
-2	20-09	COVER	1
-3	20-10	SUPPORT ARM	1
-4	10-1	FUSIBLE LINK	1
-5	20-10-3	CASTERS-SWIVEL TYPE	4
-6	20-04-3	JUNCTION BOX	1
-7	20-16	POWER CORD	1
-8	20-16-3	CONDUIT-CORD TO SWITCH	1
-9	20-04-1	FLOOR TYPE FOOT OPERATED SWITCH	1
-10	20-16-3A	CONDUIT-SWITCH TO MOTOR	1
-11	20-15	MOTOR & PUMP ASSY	1
-12	20-20	STAND PIPE ASSY	1
-13	20-11	RUBBER HOSE-SOLVENT RESISTANT	1
-14	20-11A	NOZZLE	1
-15	20-13	VALVE	3
-16	20-14	STRAINER-INTAKE	1
-17	20-29	WORK REST-29"	1
-17	20-36	WORK REST-36"	1
-18	20-08	BASKET-PARTS	1

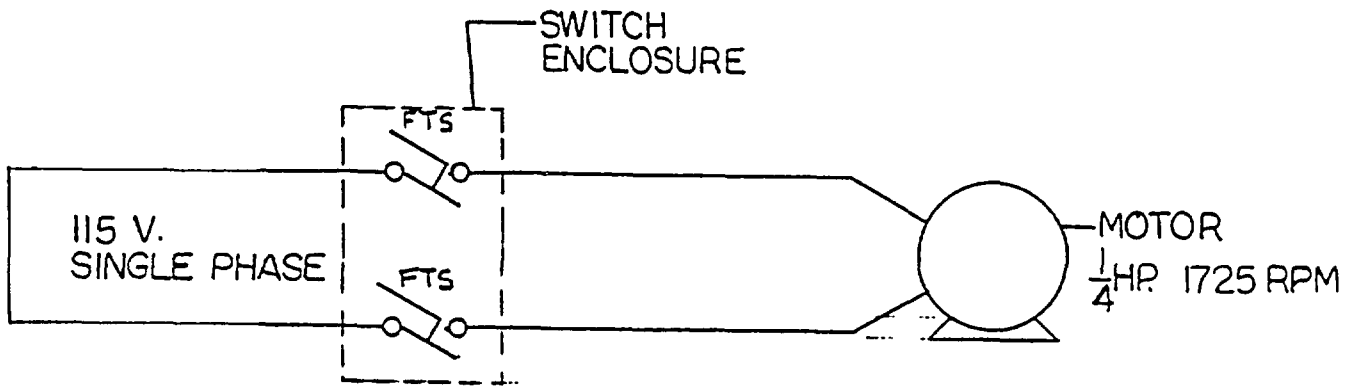

Figure 2. Circuit Diagram

By Order of the Secretary of the Army:

E. C. MEYER
General, United States Army
Chief of Staff

Official:

B. G. JOYCE
Brigadier General, United States Army
The Adjutant General

DISTRIBUTION:

To be distributed in accordance with Special List.

RECOMMENDED CHANGES TO EQUIPMENT TECHNICAL PUBLICATIONS

SOMETHING WRONG WITH THIS PUBLICATION?



THEN . JOT DOWN THE DOPE ABOUT IT ON THIS FORM. CAREFULLY TEAR IT OUT. FOLD IT AND DROP IT IN THE MAIL!

FROM (PRINT YOUR UNIT'S COMPLETE ADDRESS)

Your mailing address

DATE SENT

Date you filled out form.

PUBLICATION NUMBER

TM 9-XXXX-XXX-XX

PUBLICATION DATE

Date of TM

PUBLICATION TITLE

Title of TM

BE EXACT PIN-POINT WHERE IT IS

PAGE NO	PARA GRAPH	FIGURE NO	TABLE NO
---------	------------	-----------	----------

400

183

512

191

IN THIS SPACE TELL WHAT IS WRONG AND WHAT SHOULD BE DONE ABOUT IT:

Change illustration. Reason: Tube end shown assembled on wrong side of lever cam.

Figure 191, item 3 has the wrong NSN. Supply rejects orders for this item. The NSN shown here is not listed in the AMDF or the MCRL.

Please give us the correct NSN and P/N.

SAMPLE

PRINTED NAME GRADE OR TITLE AND TELEPHONE NUMBER

John Smith, S. SGT

793/XXXX

SIGN HERE

John Smith

DA FORM 2028-2
1 JUL 79

PREVIOUS EDITIONS ARE OBSOLETE.

IF S - IF YOUR OUTFIT WANTS TO KNOW ABOUT YOUR RECOMMENDATION MAKE A CARBON COPY OF THIS AND GIVE IT TO YOUR HEADQUARTERS

TEAR ALONG PERFORATED LINE

FILL IN YOUR
UNIT'S ADDRESS

FOLD BACK

DEPARTMENT OF THE ARMY

OFFICIAL BUSINESS
PENALTY FOR PRIVATE USE \$300

POSTAGE AND FEES PAID
DEPARTMENT OF THE ARMY
DOD 314



Commander
US Army Armament Materiel Readiness Command
ATTN: DRSAR-MAS
Rock Island, IL 61299

TEAR ALONG PERFORATED LINE

FILL IN YOUR
UNIT'S ADDRESS

FOLD BACK

DEPARTMENT OF THE ARMY

OFFICIAL BUSINESS
PENALTY FOR PRIVATE USE \$300

POSTAGE AND FEES PAID
DEPARTMENT OF THE ARMY
DOD 314



Commander
US Army Armament Materiel Readiness Command
ATTN: DRSAR-MAS
Rock Island, IL 61299

TEAR ALONG PERFORATED LINE

